

Model: SPE-O122

Installation guide

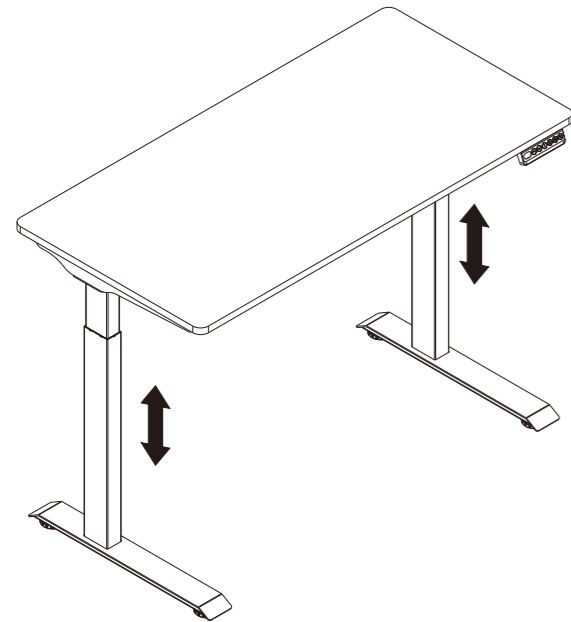

Technical Data

Column Number	2
Maximum Load	50KG
Max Speed	25mm/s
Input Voltage	100-240V
Lowest Position	730mm
Highest Position	1230mm
Desktop Size	1200mm(length) 600mm(width)
Duty Cycle	Continuous operation for 2 mins at most after pause for 18 mins
Applicable Temperature	0~40°C

Accessory List

Attention: The drawings below are only for reference which might be slightly different from the actual object, please in kind prevail. Any tools missing or installation problems, please contact the customer service firstly.

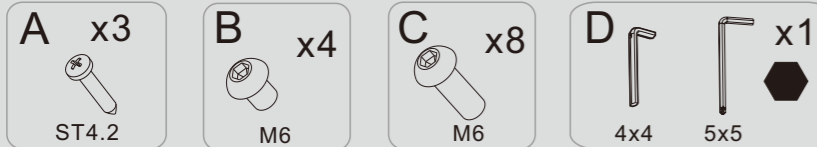

Part List

No.	Part	Qty	No.	Part	Qty	No.	Part	Qty
①	Tabletop	1	②	Lifting column	2	③	Hand switch	1
④	Feet	2	⑤	Power plug	1	⑥	Adaptor	1
⑦	Cable mounts	4	⑧	Cable	1			

Installation Instruction

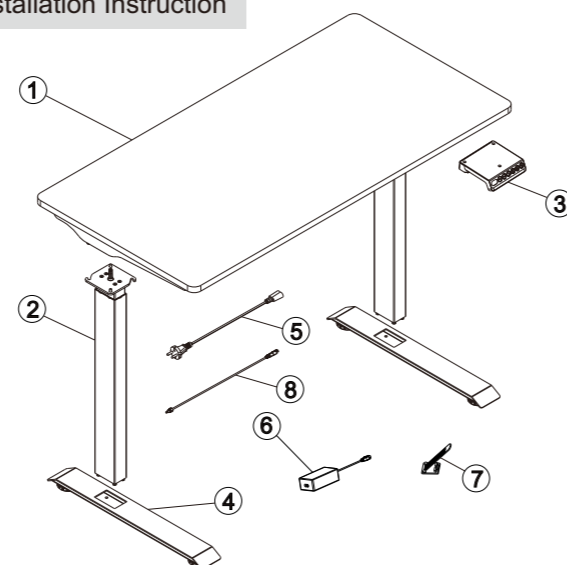

STEP1 Install the lifting column

B x4
D 4x4

! Rotate the column after inserting it to the bottom to avoid height difference

1
2

longside of the lifting column

Shortside of the desktop

1

Insert the hexagon of the column head along the guide groove

2

Rotate the column after inserting it, making the screws on the supporting beam into the column slot

3

4

Screws B

Tighten the screws(B) with 4x4 allen key

Install the lifting column (2) to the tabletop(1), then tighten the screws (B) with allen key (D)

STEP2 Install the feet

C x8
D 4x4

4

2

C

D

Install the feet (4) to the lifting columns (2) with the screw (C) and tighten it with 4*4 wrench (D)

STEP3 Install the hand switch

A x3
D 5x5

3

2

1

A

D

Position the hand switch (3) as shown in the picture to align the three underports on the tabletop, then fix it with the screw (A) and tighten it with 5*5 wrench (D)

STEP4

Connect all cables to the adaptor

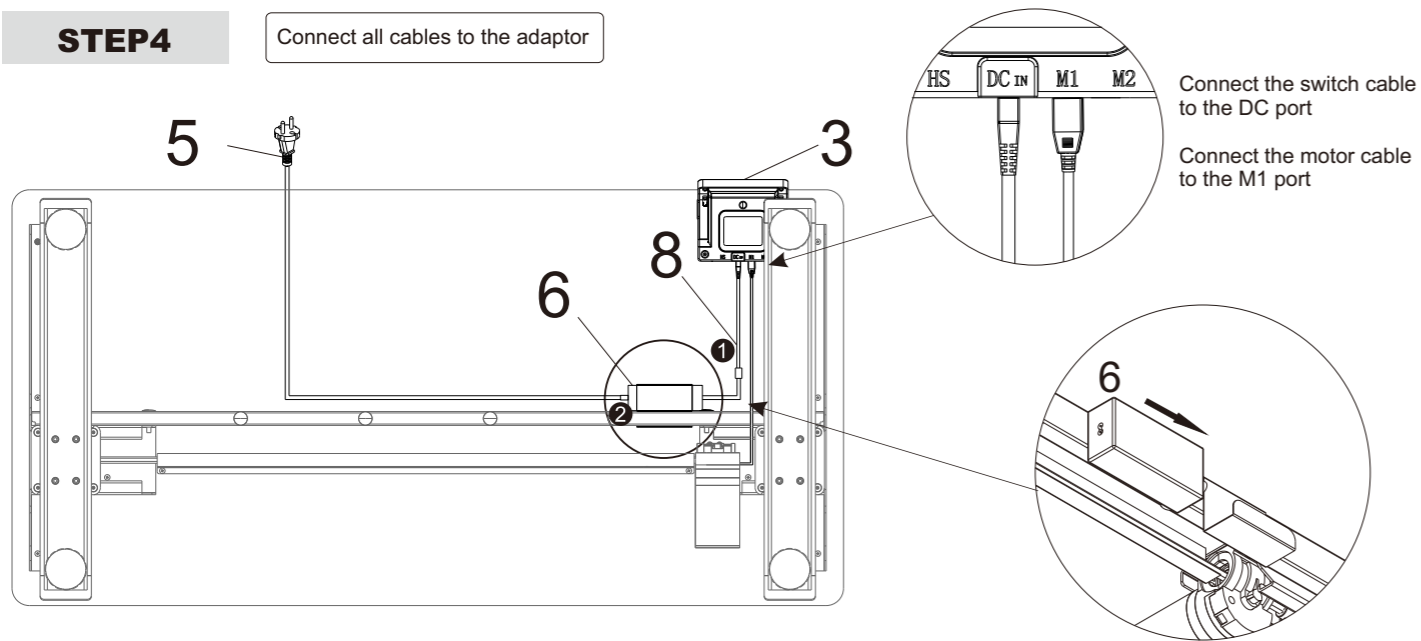

Connect the switch cable to the DC port

Connect the motor cable to the M1 port

Insert the adaptor(6) to the bracket of the tabletop

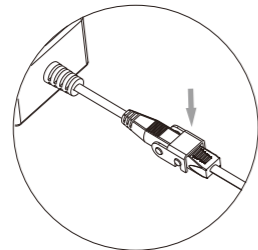
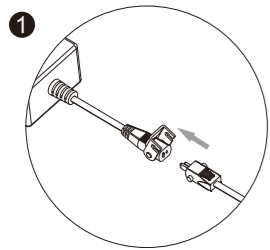

Fix the cables to the tabletop with cable management(7) to keep desk clean

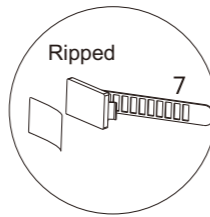
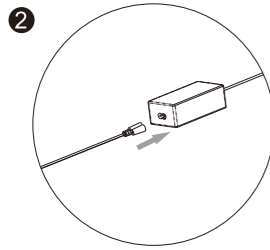

Organize the lines

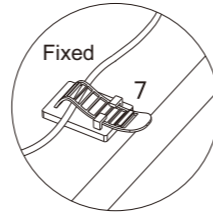

How to use handswitch

Key button

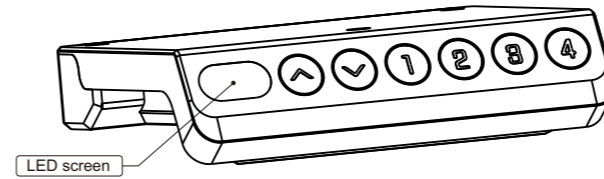

●	“▲”	Up button, adjust the desk upwards
●	“▼”	Down button, adjust the desk downwards
●	“1”	Position1, user's first stored height position
●	“2”	Position2, user's second stored height position
●	“3”	Position3, user's third stored height position
●	“4”	Position4, user's fourth stored height position

● Troubleshooting:

- Reset: When the LED shows "H5f" or "r5k", press and hold "▼" button to reset the desk, when the desktop descends to the lowest height, it will bounce upward and run until the LED shows "bot", that is, the reset is completed.
- When it doesn't work and the LED shows "E01" or "E02", please retry 18 mins later.
- If the "▼" button doesn't work, and the LED shows other code, please check the cable connection and then cut off the power for at least 10 seconds. Reconnect to the power and press "▼" button to start the reset process when it shows the "H5f" or "r5k".
- If all these above process are inefficient, plz contact our customer service.

Common fault treatment

The following tips will help you detected and eliminate the common fault and error. If the fault you met is not listed below, please contact with your supplier. Only the manufacturer and professionals are capable for investigating and correcting those fault and error.

Fault phenomenon	Method
No response while long pressing down arrow after connected with a power supply	1. Check if all the cables be connected well 2. Contact your supplier or dealer
No response while pressing up arrow/ down arrow after connected with a power supply	1. Check if all the cables be connected well 2. Contact your supplier or dealer
Rising in a low speed	1. Check if overloaded, max loading: 50kg; 2. Contact your supplier or dealer
The motor not move as instructed	1. Contact your supplier or dealer
Go down but not go up	1. Reposition 2. Contact your supplier or dealer
Downward sliding	1. Check if overloaded, max loading: 50kg; 2. Contact your supplier or dealer
Frequently Reposition	1. Check if overloaded, max loading: 50kg; 2. Contact your supplier or dealer
Overwork (Duty cycle: Max 2min on/18min OFF)	1. Restart after suspend for 18mins while connecting with power. 2. Contact your supplier or dealer;
Not enough up&down height	1. Press "3" and "4" together for 3 seconds or more, after hearing continuous beeping for twice, it will restore factory settings. 2. Contact your supplier or dealer

Operation Instruction

● Adjust Height :

- Press the "▲" button, the desk rises, long press to continue to rise, the screen will show "top" when rising to the highest point
- Press the "▼" button, the desk descends, long press to continue to descend, the screen will show "bot" when descending to the lowest point

● Memory Preset Height:

- When the desktop is stationary, long press the button "1" for 3 seconds, the buzzer will generate a sound prompt and the display shows "S-1", the save is successful, and then adjust the desktop to any height, click the button "1" to adjust the desk to the original memory height.
- Button "2", "3", "4" all have the same memory height function as Button "1", repeat the above steps.

● Reset Operation:

- When the height of the device is incorrect or an error code appears, the device needs to be reset and corrected. Long press the button "3" and button "4" simultaneously for 3 seconds to enter this function.
- After entering the reset function, the display shows "RST", long press the "▼" button to reset the device. When the desktop descends to the lowest height, it will bounce upward and run until it is displayed "bot", that is, the reset is completed.

● Adjust the Anti-Collision Sensitivity:

- Long press the "▲" button and "▼" button simultaneously for 3 seconds to switch the sensitivity. Switch 1 gear for every operation, there are 4 gear range, A-0, A-1, A-2, A-3
- When the display shows "A-0", the desk turns off the anti-collision function; "A-3" for high sensitivity; "A-2" for middle sensitivity; "A-1" for low sensitivity. (Factory default A-0)
- When the desk rises or descends, it will rebound immediately when it encounters an obstacle to protect.



Attention

- Power supply: AC100V-240V,50/60HZ
- Service Environment: 0-40°C
- Unplug the power plug before cleaning, wipe the dust on surface with slight wet dishcloth when cleaning, be careful not to let the drops into the internal parts, not loose the connector.
- The electric box contains electronic components, metals, plastics, wires etc., so dispose of it in accordance with each country's environmental legislation, not the general household waste.
- Check carefully to ensure correct and complete assembly before using.
- Be familiar with all functions and program settings of the product before first use.
- Children are forbidden to play on the product because of unforeseen action when playing, so any dangerous consequences caused by this improper action will not be on manufacturers.
- Slight noise caused by the V-ribbed belt or brake system due to structure will not have any effect on the use of the equipment.
- Corrosive or abrasive materials are forbidden to clean the equipment. Must ensure that the cleaner used will not pollute the environment.
- This appliance can be used by children aged from 8 years and above and persons with reduced physical, sensory or mental capabilities or lack of experience and knowledge if they have been given supervision or instruction concerning use of the appliance in a safe way and understand the hazards involved. Children shall not play with the appliance.
- Cleaning and user maintenance shall not be made by children without supervision.
- If the supply cord is damaged, it must be replaced by the manufacturer, its service agent or a similarly qualified person in order to avoid a hazard.
- Please make sure there is no hazard sources in your operating environment. e.g., do not litter the tools around. Always be careful to treat the packaging materials in order to avoid any possible danger, e.g. plastic bag may lead to choking hazard to children.
- Keep the original package of the equipment if necessary in case of the future use in transportation.

Waste disposal



This marking indicates that this product should not be disposed with other household wastes. To prevent possible harm to the environment or human health from uncontrolled waste disposal, recycle it responsibly to promote the sustainable reuse of material resources. To return your used device, please use the return and collection systems or contact the retailer where the product was purchased. They can take this product for environmental safe recycling.

Made in ChRL for
DMTrade Mikołaj Tomaszewski
Wiśniowa 36, 64-000 Kościan, Poland

NIP: PL6981681757
email: sklep@dmtrade.pl
phone #1: +48 661 082 052
phone #2: +48 726 082 052

www.ergoline.spacetronek.eu